

ENERGIZER CR1220

Lithium Coin



Industry Standard Dimensions

mm (inches)



This Battery has Underwriters Laboratories component Recognition

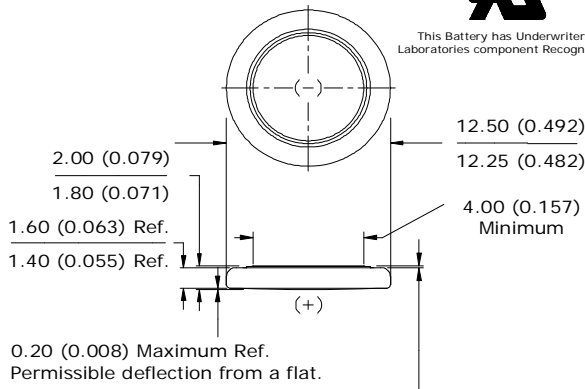

Simulated Application test

Typical Performance at 21°C (70°F)

Schedule:	Typical Drains: at 2.85V (mA)	Load (ohms)	Cutoff 2.0V (hours)
Continuous	0.064	45,000	628

Typical Discharge Characteristics

Load: 45K ohms - Continuous
Typical Drain @ 2.9V: 0.064 mA

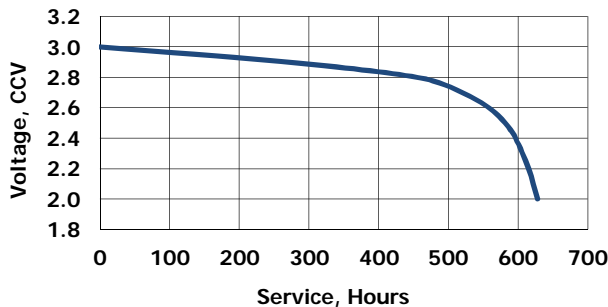

Internal Resistance Characteristics

Pulse Test at 21°C (70°F)

Bkgnd Drain: Continuous
62K ohms
0.046 mA @ 2.85V

Pulse Drain: 2 seconds X 12 times/day
1K ohms
2.8 mA @ 2.65V

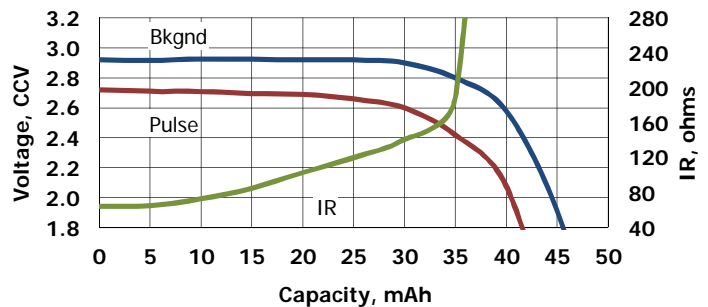

Important Notice

This datasheet contains typical information specific to products manufactured at the time of its publication.
©Energizer Holdings, Inc. - Contents herein do not constitute a warranty.

Specifications

Classification: "Lithium Coin"
Chemical System: Lithium / Manganese Dioxide (Li/MnO₂)
Designation: ANSI-5012LC, IEC-CR1220
Nominal Voltage: 3.0 Volts
Typical Capacity: 40 mAh (to 2.0 volts)
 (Rated at 45K ohms at 21°C)
Typical Weight: 0.78 grams (0.03 oz.)
Typical Volume: 0.25 cubic centimeters (0.02 cubic inch)
Max Rev Charge: 1 microampere
Energy Density: 153 milliwatt hr/g, 464 milliwatt hr/cc
Typical Li Content: 0.006 grams (0.0002 oz.)
UL Listed: MH12454
Shipping: For complete details, please reference:
 Global (except US): Special Provision A45 of the International
 Air Transport Association Dangerous
 Goods Regulations
 United States: 49 CFR 173.185

Safety :



1) KEEP OUT OF REACH OF CHILDREN. Swallowing may lead to serious injury or death in as little as 2 hours due to chemical burns and potential perforation of the esophagus. **Immediately see doctor; have doctor phone (202) 625-3333.**

(2) Battery compartment design. To prevent children from removing batteries, battery compartments should be designed with one of the following methods: a) a tool such as screwdriver or coin is required to open battery compartment or b) the battery compartment door/cover requires the application of a minimum of two independent and simultaneous movements of the securing mechanism to open by hand. Screws should remain captive with the battery door or cover.